



COMPASS™ CR SERIES

Portable Scales



Quality Portable Electronic Scales Suitable for Everyday Weighing

The Compass CR series provides basic weighing functionality and competitive performance at an economical price. Features such as a slim, stackable design, and an enlarged weighing platform, make the CR series perfect for a variety of portable weighing applications.

Standard Features:

- Intuitive two-button design makes for easy operation.
- Slim, space-saving design allows for stackable storage.
- Enlarged weighing platform can adequately handle large samples and a variety of objects.

COMPASS™ CR SERIES *Portable Scales*

Model	CR221	CR621	CR2200	CR5200
Capacity (g)	220	620	2200	5200
Readability (g)	0.1		1	
Span Calibration Mass (Not Included)	200 g	500 g	1 kg	2 kg
Stabilization Time (s)	2			
Construction	ABS housing and pan			
Calibration	User-selectable external span / Digital with external weight			
Tare Range	Full capacity by subtraction			
Weighing Units*	g, ozt, dwt, lb:oz			
Application Modes	Weighing			
Power Requirement	3 AA batteries (included) or AC adapter (not included)			
Typical Battery Life	300 hours			
Display Type	Liquid crystal display (LCD)			
Display Size	15 mm digits			
Pan Size (W × D)	125 × 132 mm			
Balance Dimensions (W × D × H)	140 × 205 × 41 mm			
Shipping Dimensions (W × D × H)	170 × 235 × 55 mm			
Net Weight	0.4 kg			
Shipping Weight	0.6 kg			

* Availability is dependent on model.

Other Standard Features and Equipment

ABS housing and pan, slip-resistant feet, stability indicator, mechanical and software overload/underload protection, auto shut-off

Compliance

- **Product Safety:** IEC/EN 61010-1
- **Electromagnetic Compatibility:** IEC/EN 61326-1 Class B, Basic environments; FCC Part 15 Class B; Canada ICES-003 Class B
- **Compliance Marks:** CE; RCM

Accessories

Carrying Case	30467763
Bowl, 1050 mL	80850075
Adapter with plugs (EU-US-UK-AU-KR)	30467987
Adapter, 12V 0.5A, fixed UK plug	30043166

Dimensions

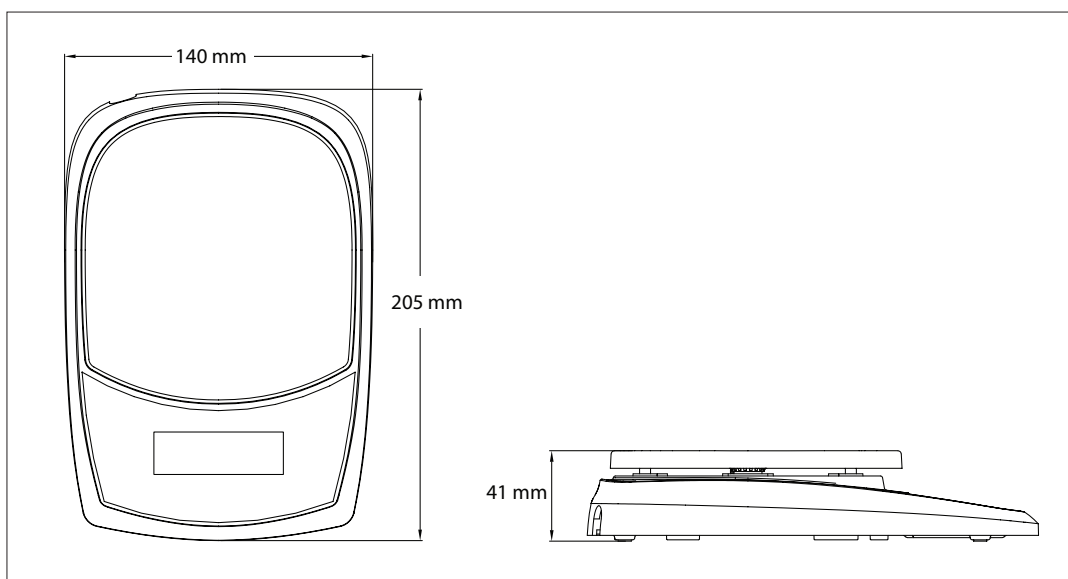

80775693_A 20190526 © Copyright OHAUS Corporation





WolfLabs

Pricing on any accessories shown can be found by keying the part number into the search box on our website.

The specifications listed in this brochure are subject to change by the manufacturer and therefore cannot be guaranteed to be correct. If there are aspects of the specification that must be guaranteed, please provide these to our sales team so that details can be confirmed.

www.wolflabs.co.uk

Tel : 01759 301142

Fax : 01759 301143

sales@wolflabs.co.uk

Please contact us if this literature doesn't answer all your questions.